

# Chinese Architecture

China has maintained the highest degree of cultural continuity across its 4000 years of existence. Its architectural traditions were very stable until the 19<sup>th</sup> c. China's strong central authority is reflected in the Great Wall and standard dimensions for construction.

Since the Tang Dynasty (7<sup>th</sup>-10<sup>th</sup> c.), Chinese architecture has had a major influence on the architectural styles of Korea, Vietnam, and Japan.



# Neolithic Houses at Banpo, ca 2000 BCE

These dwellings used readily available materials—wood, thatch, and earth—to provide shelter. A central hearth is also part of many houses.

The rectangular houses were sunk a half story into the ground.

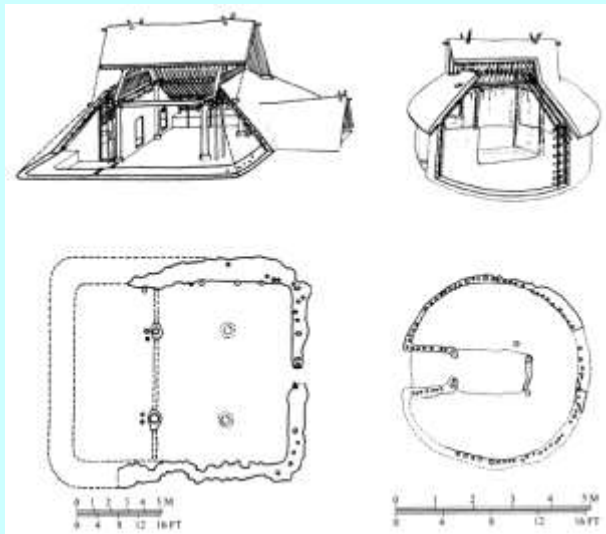



**The Great Wall of China, 221 BCE-1368 CE. 19-39' in height and 16' wide.**

Almost 4000 miles long. Begun in pieces by feudal lords, unified by the first Qin emperor and largely rebuilt and extended during the Ming Dynasty (1368-1644 CE)

Originally the great wall was made with rammed earth but during the Ming Dynasty its height was raised and it was cased with bricks or stones.

#### THE GREAT WALL OF CHINA

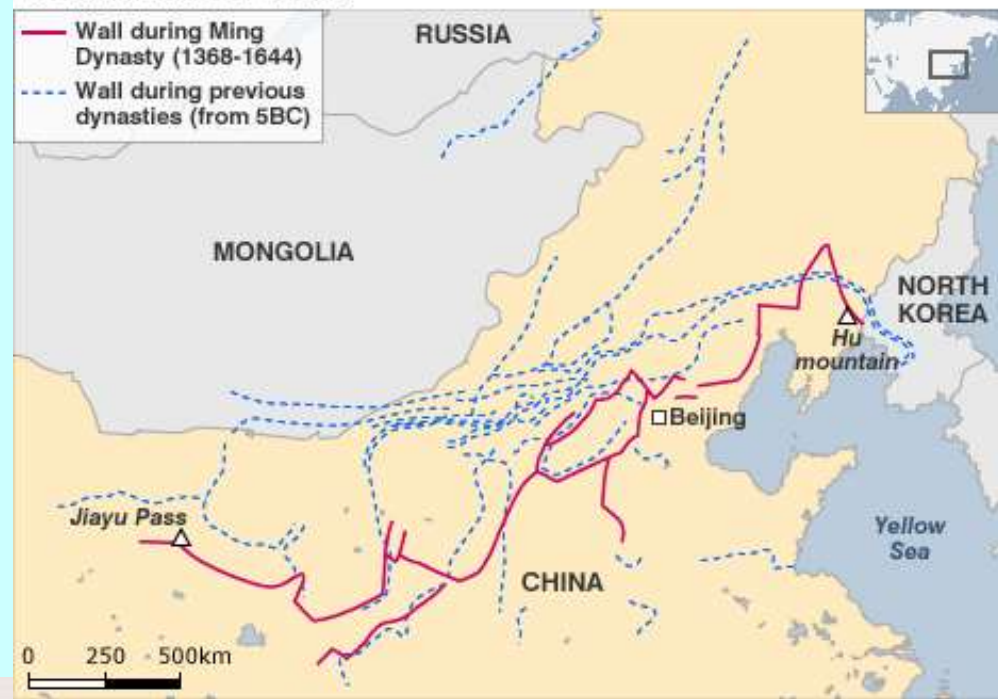

<https://youtu.be/o9rSlyxJIIE> 1;05

Deified Lao Tzu.  
8th - 11th c.



**Taoism or Daoism** is a Chinese mystical philosophy traditionally founded by Lao-tzu in the sixth century BCE.

It seeks harmony of human action and the world through study of nature.

It tends to emphasize effortless action, "naturalness", simplicity and spontaneity.

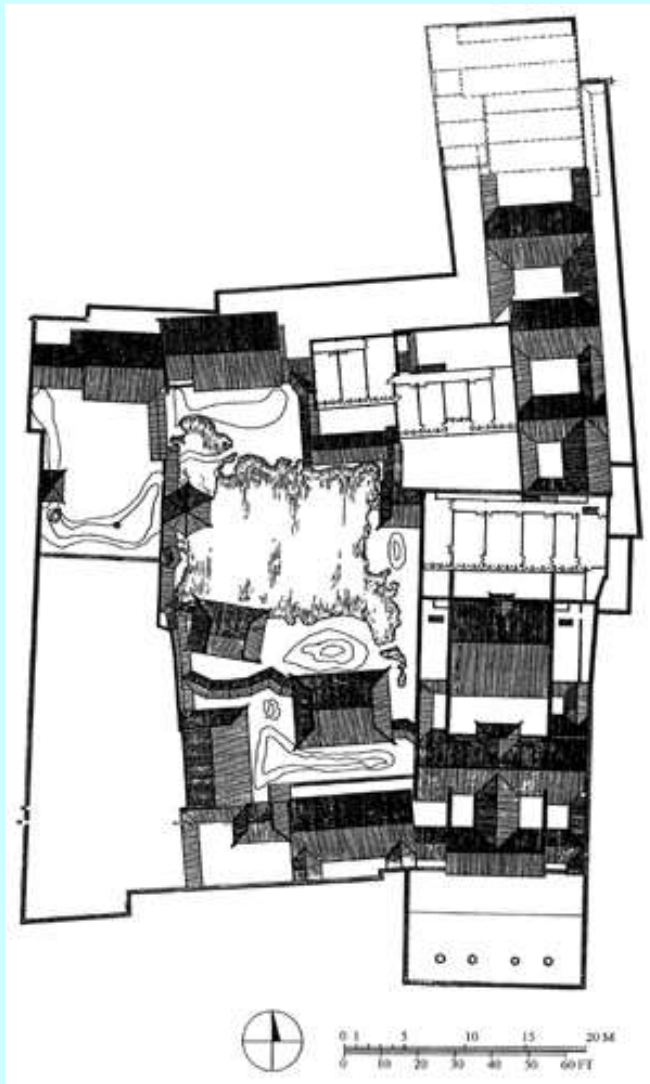

*Garden of the Master of the Fishing Nets in Suzhou, 1140.*  
Renovated in 1785

*Life is a series of natural and spontaneous changes. Don't resist them – that only creates sorrow. Let reality be reality. Let things flow naturally forward in whatever way they like. -Lao Tzu*

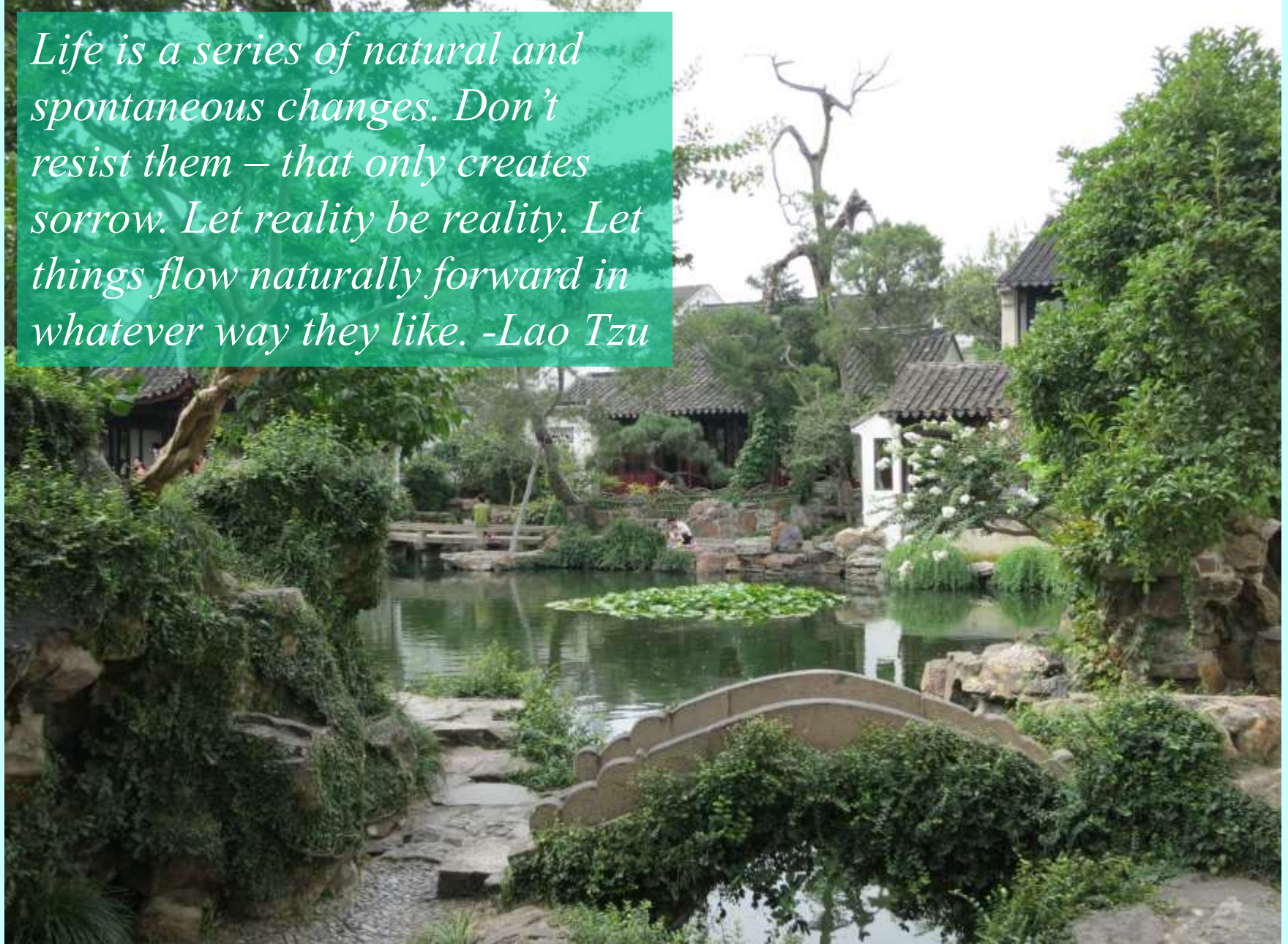

***Garden of the Master of the Fishing Nets in Suzhou, 1140. Renovated in 1785***

# Chinese City Planning

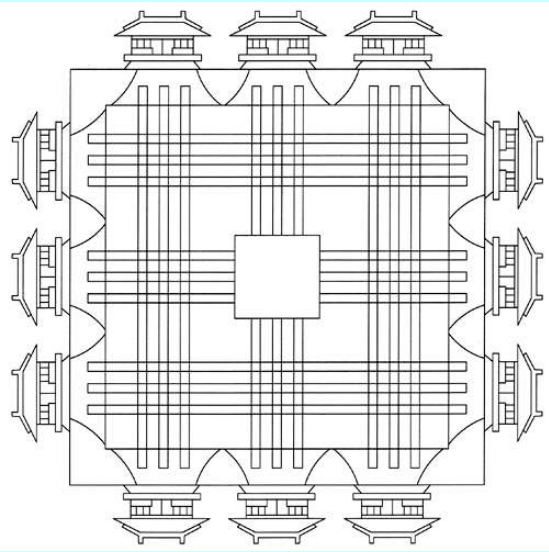

*City Diagram*  
dating to the Zhou  
Dynasty (c. 1046  
BC–256 BC)



*A portrait of Confucius*  
by the Tang dynasty artist  
Wu Daozi (680–740)

**Confucianism** developed in the 5-6<sup>th</sup> c. BCE from the teachings of the Chinese philosopher Confucius. It relied on respect for authority, the emperor, the elders of the family. It emphasizes self-control and harmony in thought and conduct.

Chinese city planning and traditional house design embodied Confucian principles in their layouts and axial alignments of buildings.

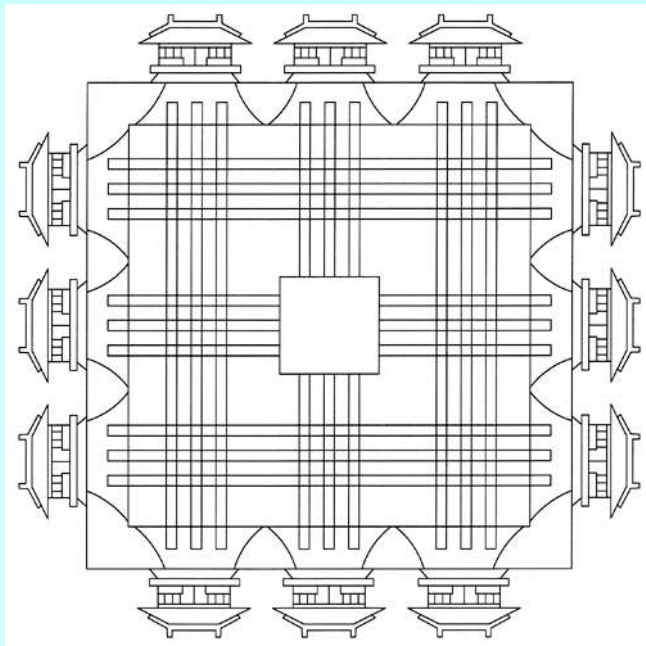

***City Diagram***  
*dating to the Zhou*  
*Dynasty (c. 1046*  
*BC–256 BC)*

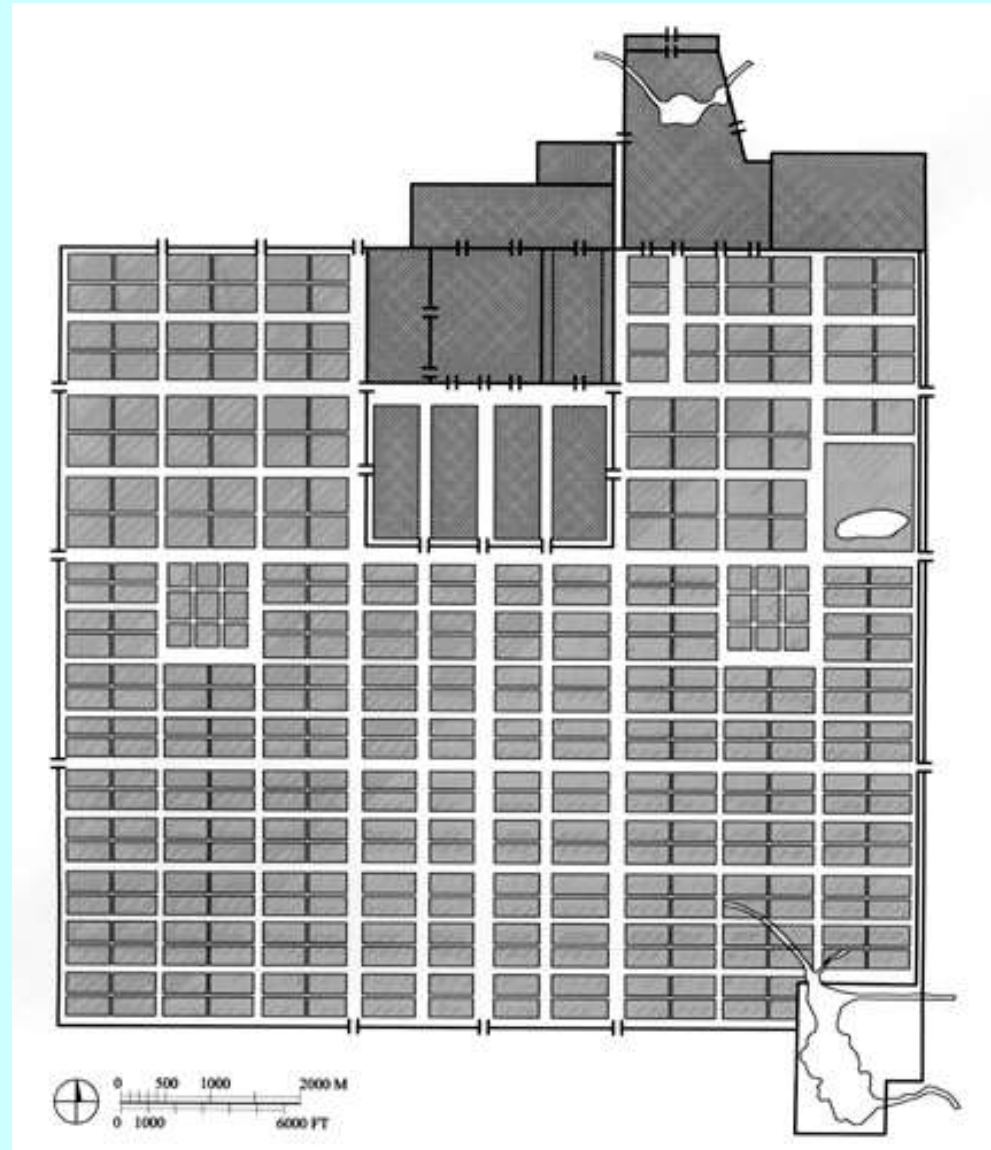

***Plan of Chang'an, the ancient capital of China. 6<sup>th</sup> c.***



## *Plan of the Forbidden City. Beijing.*

It served as the home of emperors and their households as well as the ceremonial and political center of Chinese government for almost 500 years. The complex consists of 980 buildings and covers over 180 acres.

[https://youtu.be/6QvsCr\\_xK3c](https://youtu.be/6QvsCr_xK3c)



### *Hall of Supreme Harmony*

15- 17<sup>th</sup> c. It was the ceremonial center of imperial power, and the largest surviving wooden structure in China.

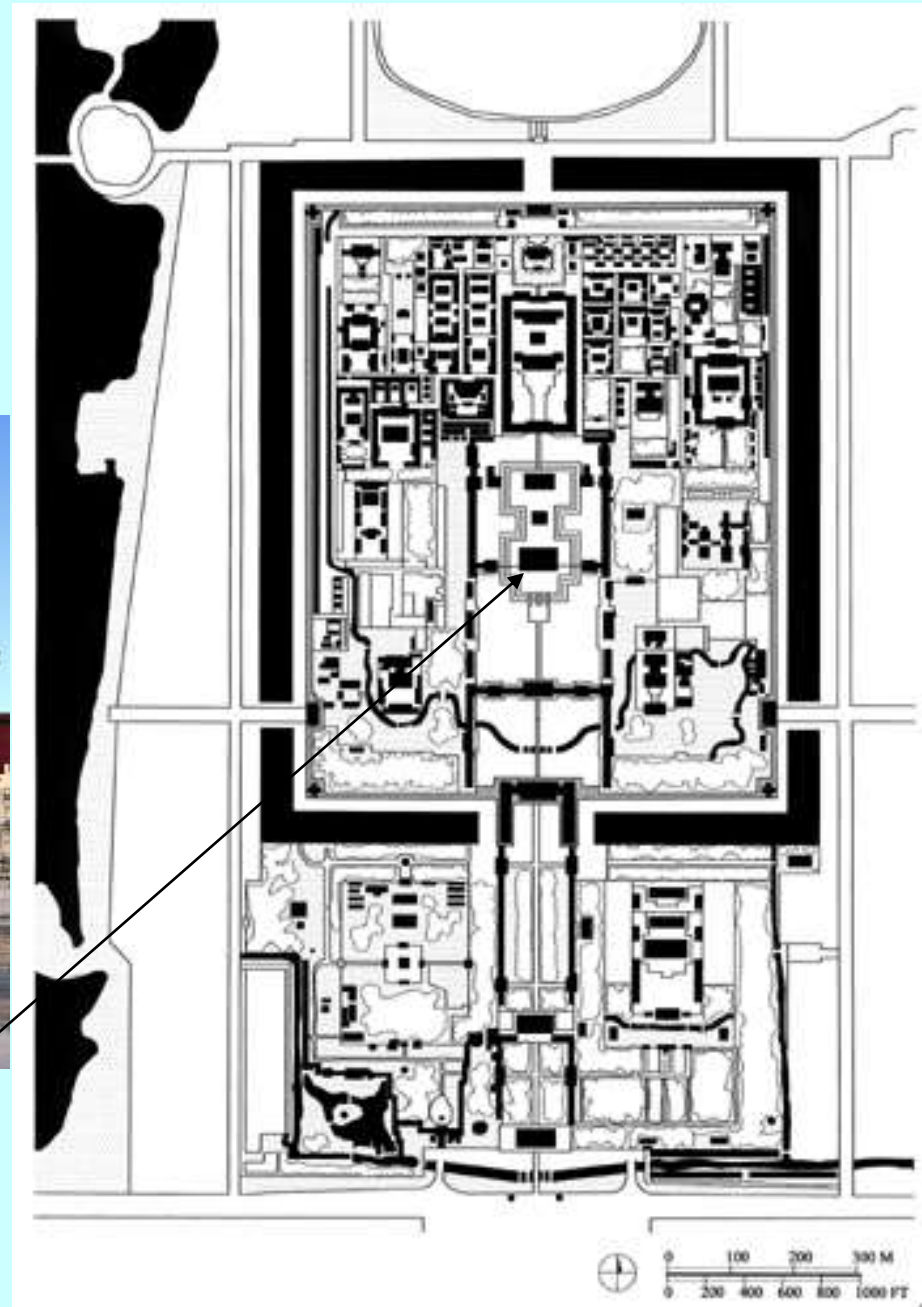



The throne and interior of the Hall of Supreme Harmony is filled with symbols of power and of imperial rule.

# Chinese Architectural Principles:

- Primary material – **wood**
- Primary construction technique – **post and lintel**
- System of brackets to distribute the weight of the roof.
- Basic measure – modular unit called the **jian** (about 12X20’).

# The jian

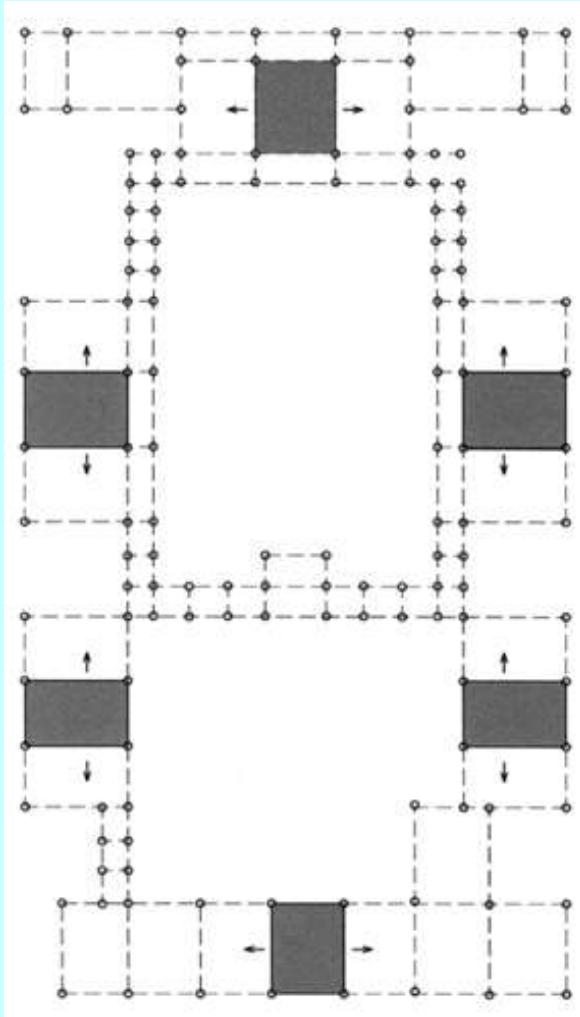

## *Diagram of a typical Chinese house.*

The jian, a rectangular module roughly 2:3 in proportion, serves as the basic unit for wooden construction. Houses tend to be built with separate pavilions for different functions, and they are generally arranged around courtyards, with axial position determining hierarchy and importance.

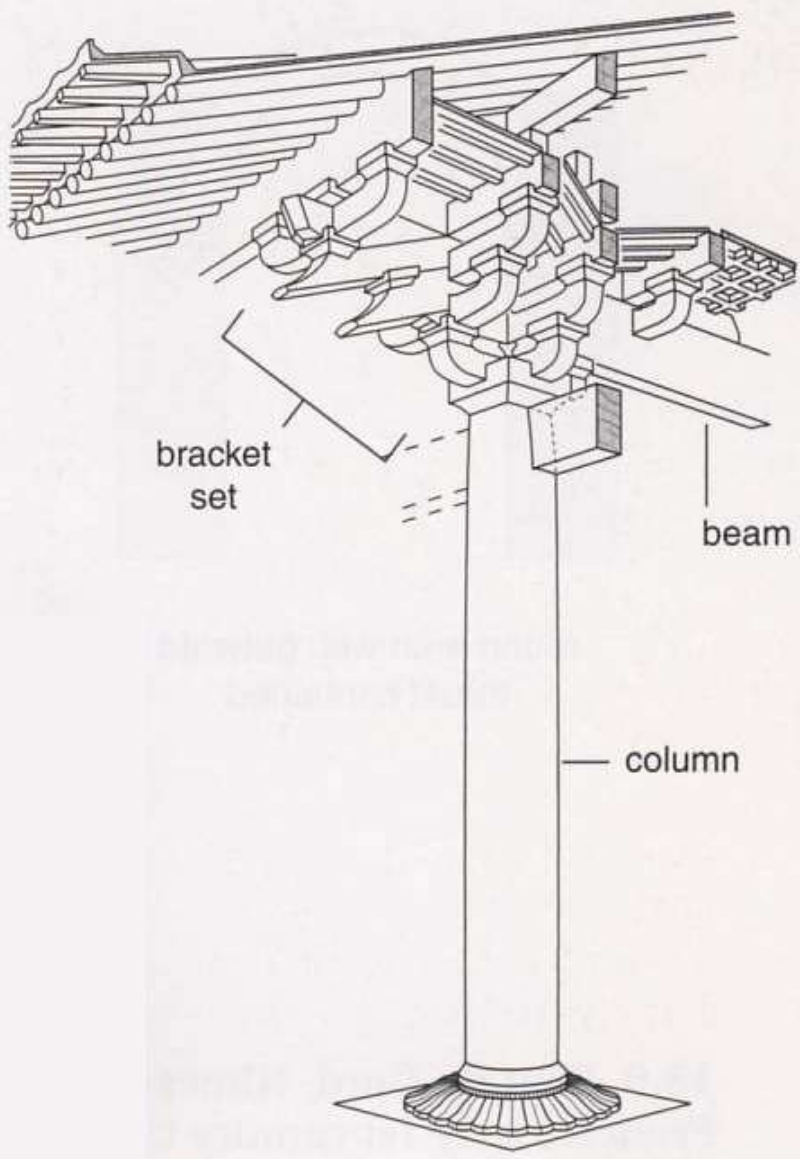

Bracket system



Reconstruction of Chinese Temple Bracket

**Buddhism** a religion of eastern and central Asia growing out of the teaching of Siddhārtha Gautama (Buddha) that life is full of suffering caused by desire and that the way to end this suffering is through enlightenment that enables one to halt the endless sequence of births and deaths to which one is otherwise subject.

In Buddhism, buddhahood is the condition or rank of a buddha "awakened one".



Classical-Buddhist statue of standing Buddha, Gandhara - Pakistan (1st–2nd century A.D.), Tokyo National Museum

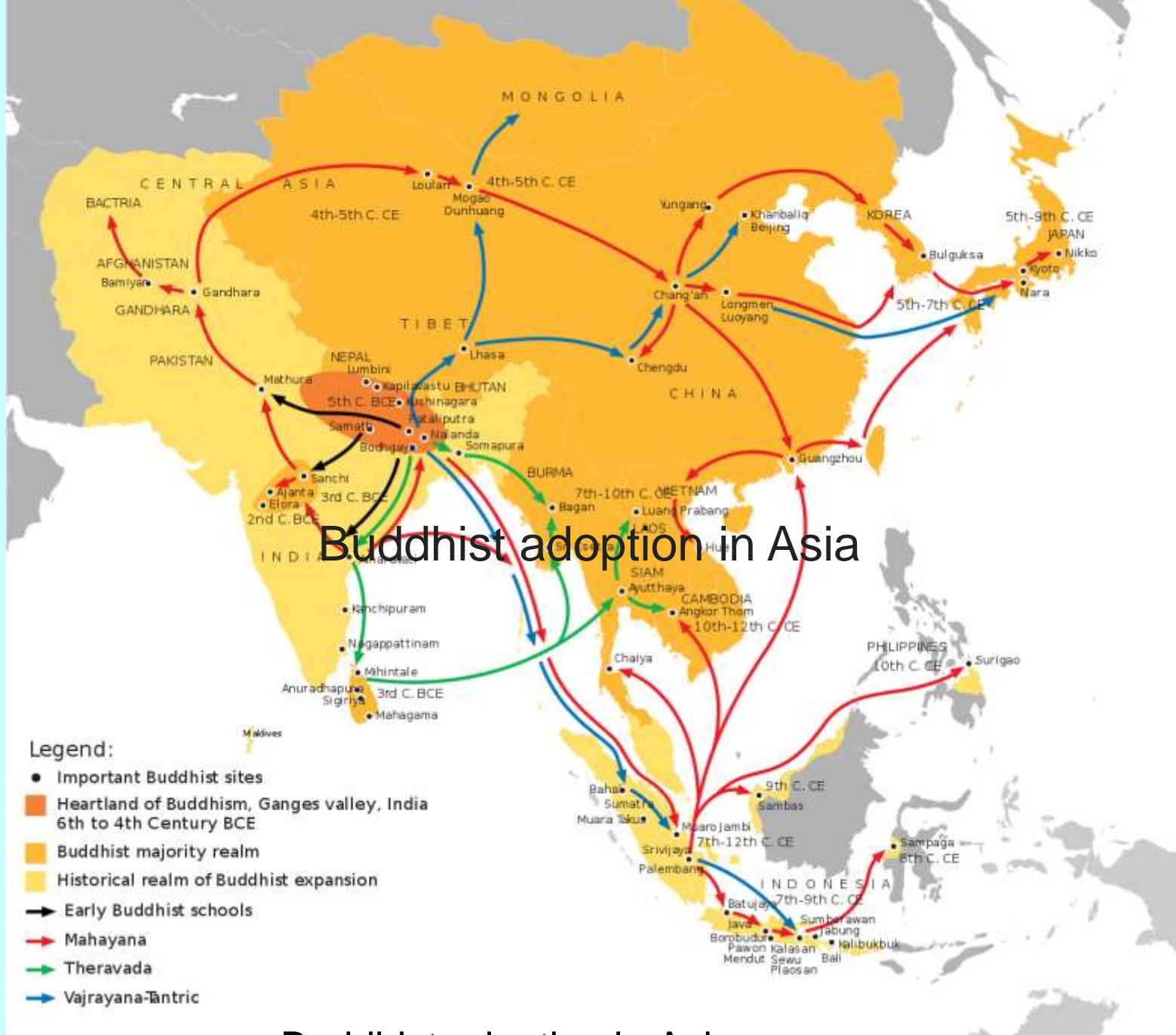

Buddhist adoption in Asia

It is the third oldest dated  
wooden building in China

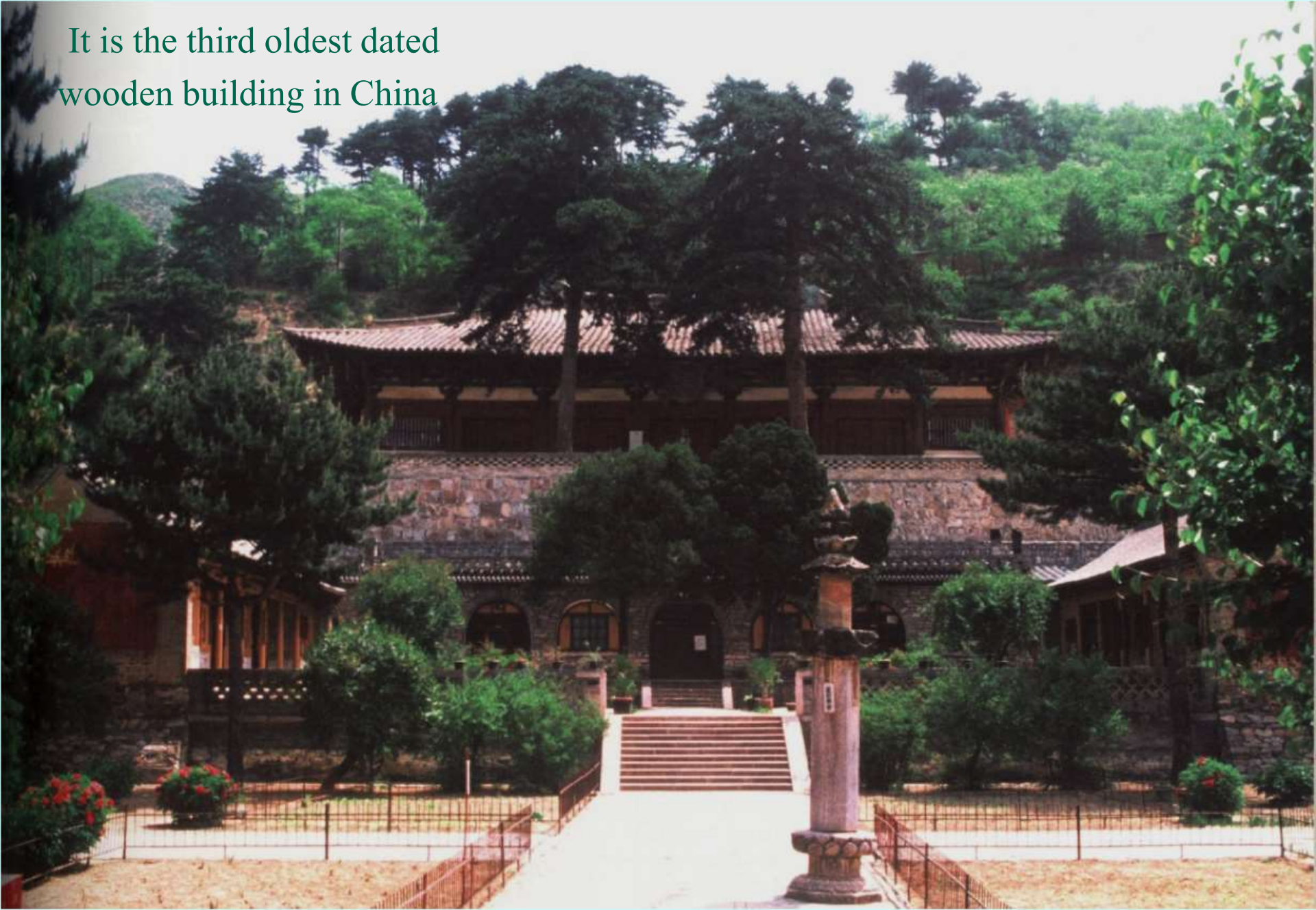

***Great East Hall, Fuguang Temple (Buddhist temple).*** Shanxi province, China 857 AD



# Fuguang Temple

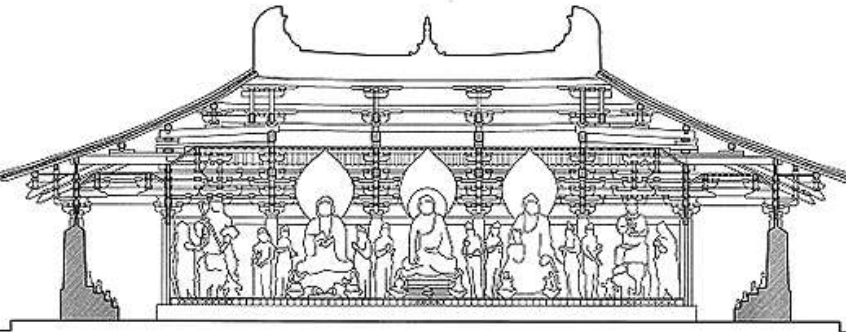
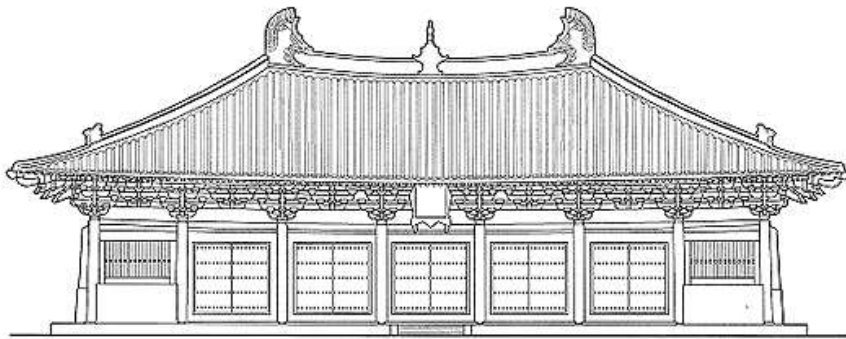

0 1 5 10 M  
0 10 20 30 FT

The challenge in this temple was to span a larger space in the center without additional columns.

*Elevation and longitudinal section of the Main Hall of Fuguang Temple*

# Fuguang Temple

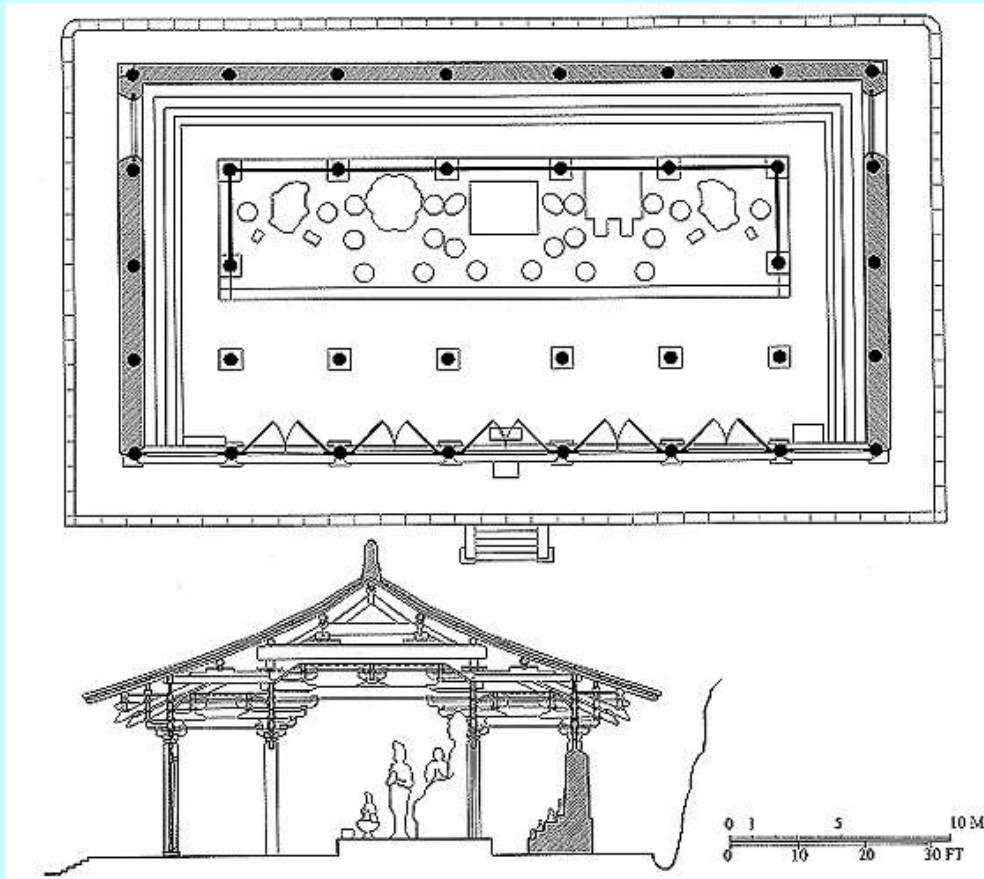

*Plan and transverse section of the Main Hall of Fuguang Temple, 857.*

Here the landscape has been terraced to create a higher platform for the Main Hall, which is set on axis in the position of greatest importance.

It is the oldest surviving brick structure in China and oldest surviving pagoda.

## **Pagoda –**

a towerlike, multistory, solid or hollow structure made of stone, brick, or wood, usually associated with a Buddhist temple complex; usually found in East and Southeast Asia.

The pagoda's original purpose was to house relics and sacred writings.

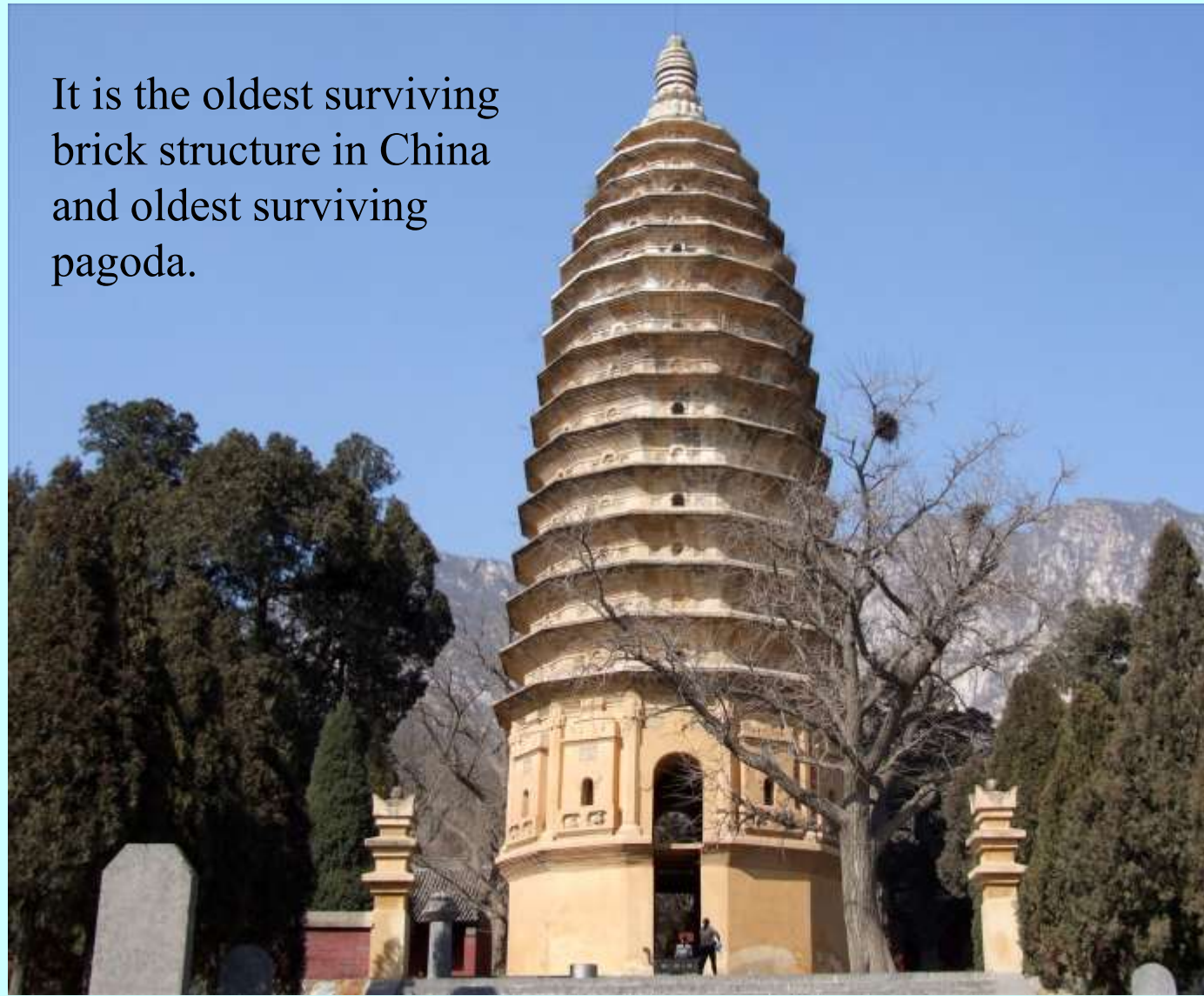

Songyue Pagoda. 523 AD. Located at the Songyue Monastery, Henan province, China. 130 foot tall. 12-sided, 15-tiered, brick.

# Indian Stupa

*The finial is called chatra*

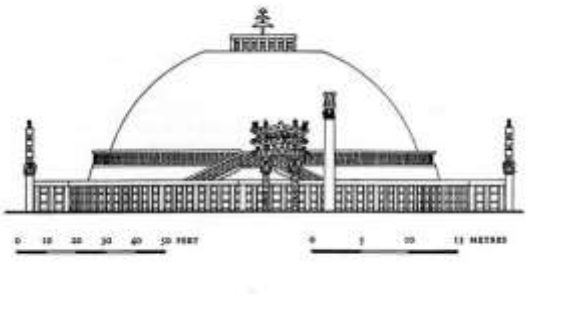

***The Great Stupa, Sanchi, India***, completed in the 1st century AD. H: 54 ft, diameter: 120 ft.

A symbolic mount for the death of Buddha, an object of adoration and a receptacle for relics. <https://youtu.be/NJsLHcL3Bvs>

The stupa came to represent the Buddha seated in meditation. The base represents his crossed legs. The middle is the body and the top of the mound, where a pole rises from the apex surrounded by a small fence, represents his head.

*Seated Buddha, 200–300. Pakistan Asian Art Museum. SF*

*The Great Stupa, 1<sup>st</sup> c. Sanchi, India*



# Stupa Origins

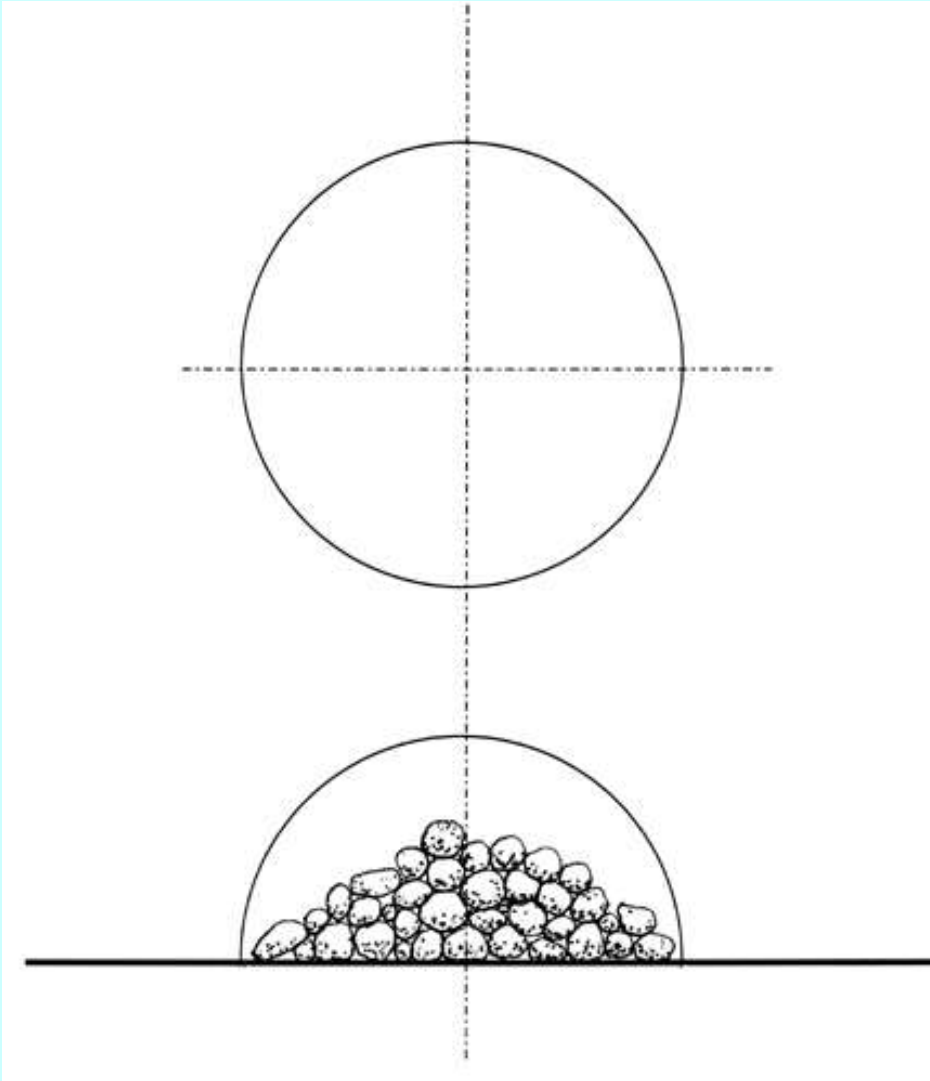

The traditional practice of placing stones and earth over the graves of distinguished people evolved into the construction of a hemispherical form that incorporated the cosmological associations of a circle, the world-mountain and dome of the heavens, and the vertical world axis.

*Treasury of Atreus*, Mycenae,  
Greece, ca. 1300–1250 BCE.  
Approx. 43' high.

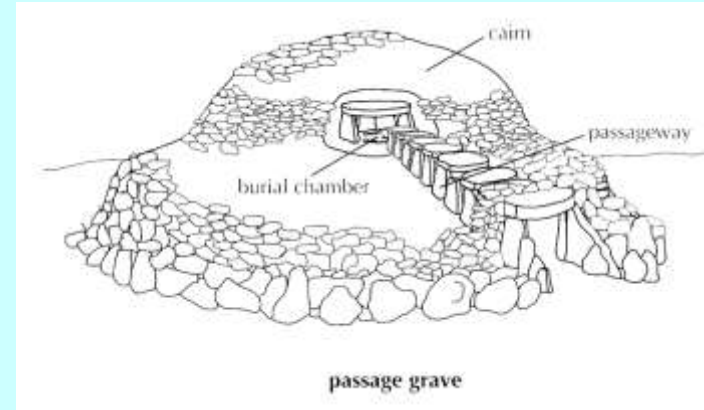

*Neolithic Passage Grave at  
Newgrange,  
Ireland. c. 3100 BCE*



*The Great Stupa*, Sanchi, India, completed in  
the 1st century AD. H: 54 ft, diameter: 120 ft.



***Pagoda of Fogong Temple.***

Yingxian, China, 1056.

It stands on a 4 m (13 ft) tall stone platform, has a 10 m (33 ft) tall spire, and reaches a total height of 67.31 m (220.83 ft) tall.

It is the oldest existent fully wooden pagoda still standing in China.







釋迦塔

天宮高齊

正古

天柱地軸

萬古觀瞻

萬古觀瞻

*Pagoda of Fogong Temple.*  
Yingxian, 1056.

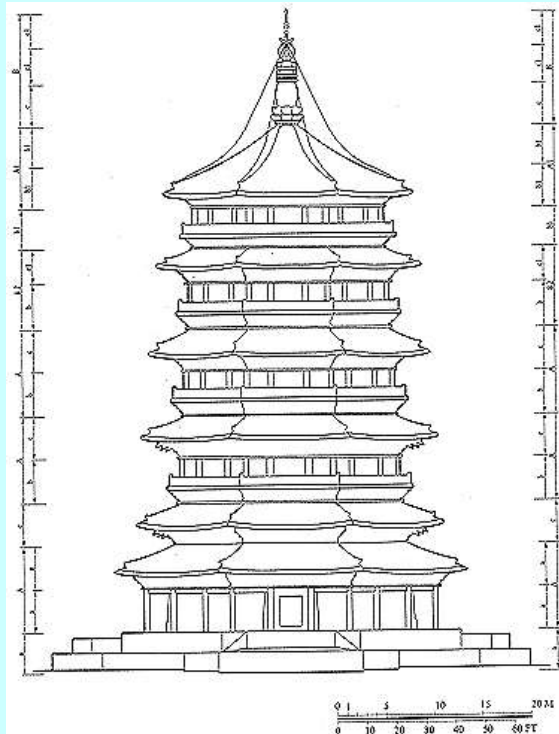

# Japanese Architecture

# Japanese Temple: Horyu-ji, near Nara

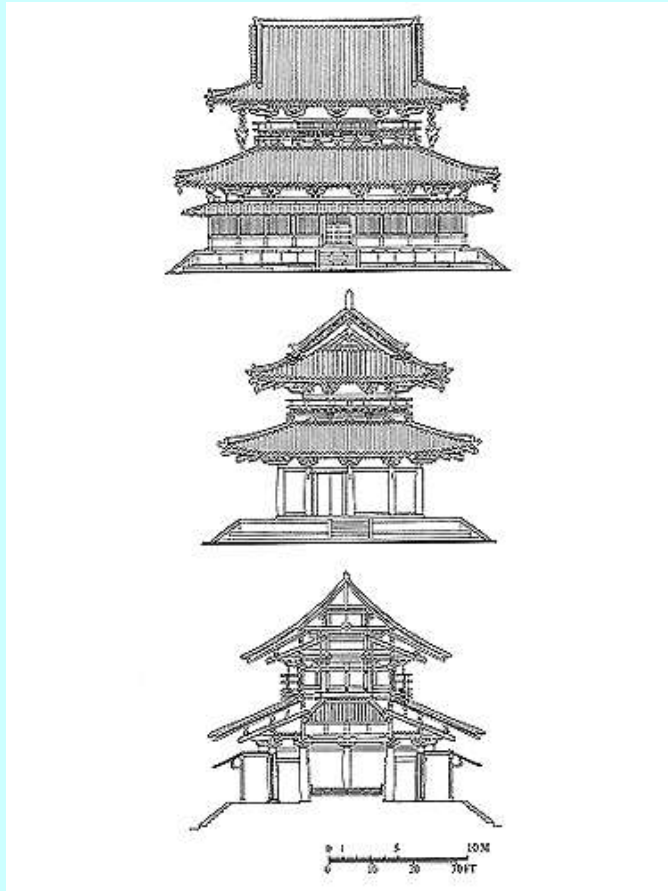

*Elevations and section of the Kondo or Golden Hall at Horyu-ji, showing the complex roof structure and eave brackets based on Chinese temple designs.*

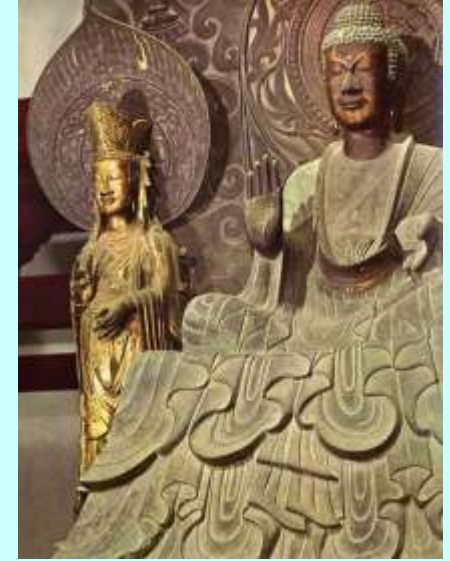

The main worship statue in the Golden Hall is Shakyamuni (historical Buddha), flanked by attendants. The statue, dated 623 A.D., is attributed to Tori Busshi.



[https://youtu.be/r4rWWtSWf\\_k](https://youtu.be/r4rWWtSWf_k)

***Kondo (Golden Hall), Horyu-ji Temple, Nara, Japan, 670-714.***  
One of the oldest wooden buildings existing in the world





Elevation and section of the pagoda at Horyu-ji.

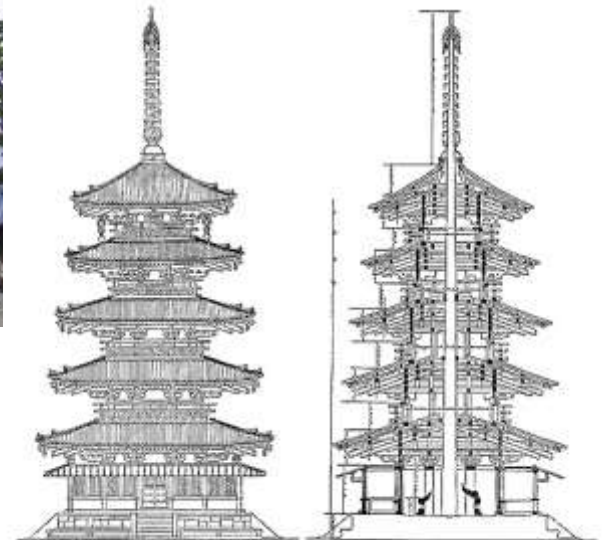

# Japanese City Plan

## Heian Capital

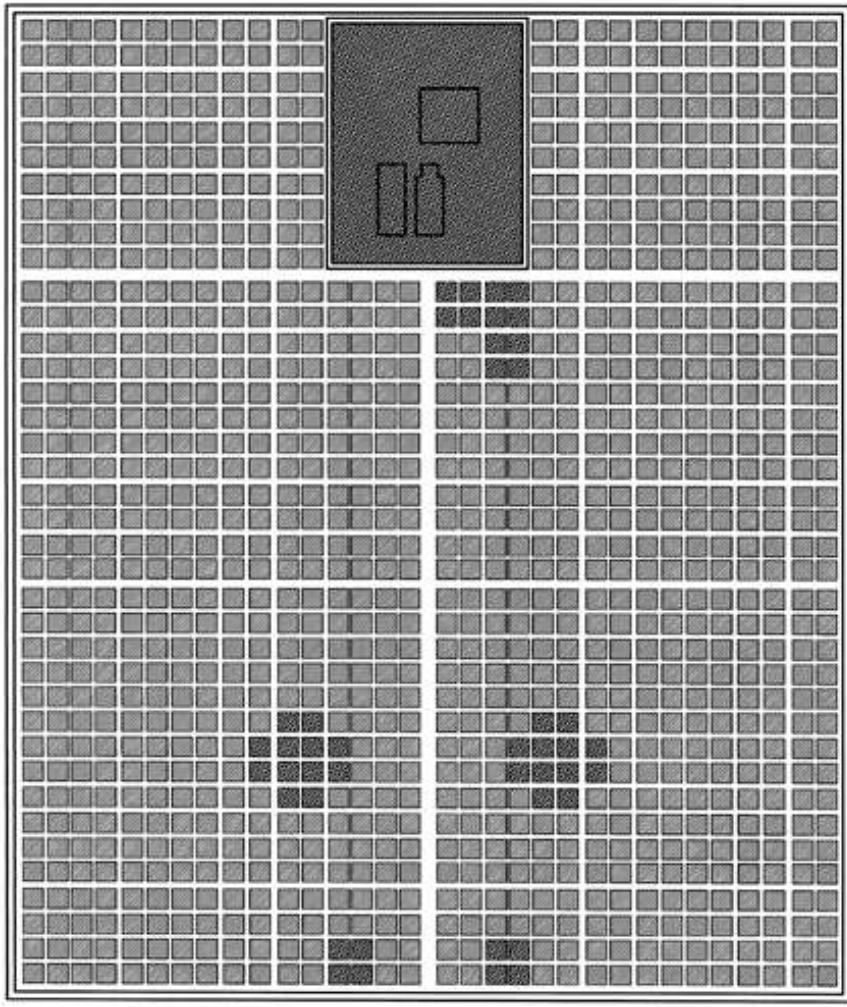

Plan of the Heian capital, ca. 794. Here one can see influence from Chinese city planning, maintaining similar orientation, grids of blocks, and placement of the palace compound as was found at Chang'an and Beijing.

The modern city of Kyoto has developed on this site without retaining the ancient plan.

# Hindu Shrine in Cambodia: Angkor Wat



A Hindu temple is a symbolic house (or palace), seat and body of god. It is a structure designed to bring human beings and gods together.

*Angkor Wat*, Cambodia, 12th-13th century AD. A Hindu temple dedicated to Vishnu

<https://youtu.be/RscOlSFnM1o> 6:40



Originally constructed as a Hindu temple dedicated to the god Vishnu for the Khmer Empire, Angkor Wat was gradually transformed into a Buddhist temple. It was built by King Suryavarman II in the capital of the Khmer Empire, as his state temple and eventual mausoleum.



# Hindu Shrines

## Angkor Wat

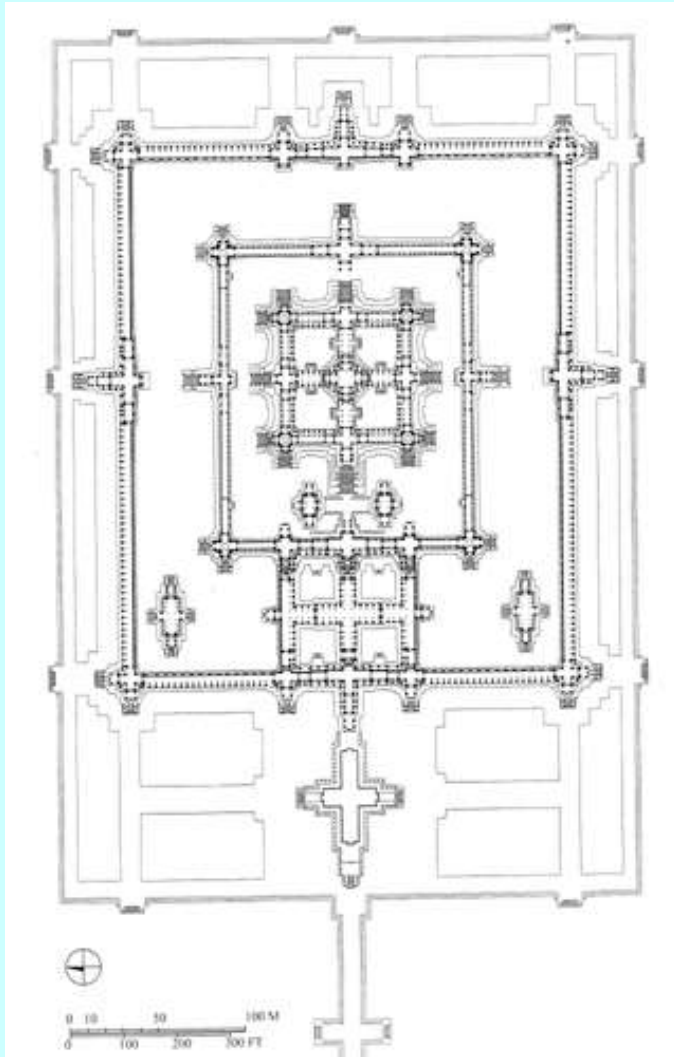

Plan of Angkor Wat.

Nested sets of galleries focus on the central shrine, the symbolic representation of Mount Mehru, home of the gods.

The complex rises from a surrounding moat representing the primordial sea out of which the sacred mountain rises.



*Angkor Wat*, Cambodia, 12th-13th century AD. A Hindu temple



*The Great Stupa, Sanchi, India*, completed in the 1st century AD. H: 54 ft, diameter: 120 ft.



*Pagoda of Fogong Temple*.  
Yingxian, China, 1056.

Compare and contrast a stupa, a pagoda and a Hindu temple. Who built them? for what purpose/s? How were they used? Symbolism, etc.